

Chesterfield Armchair

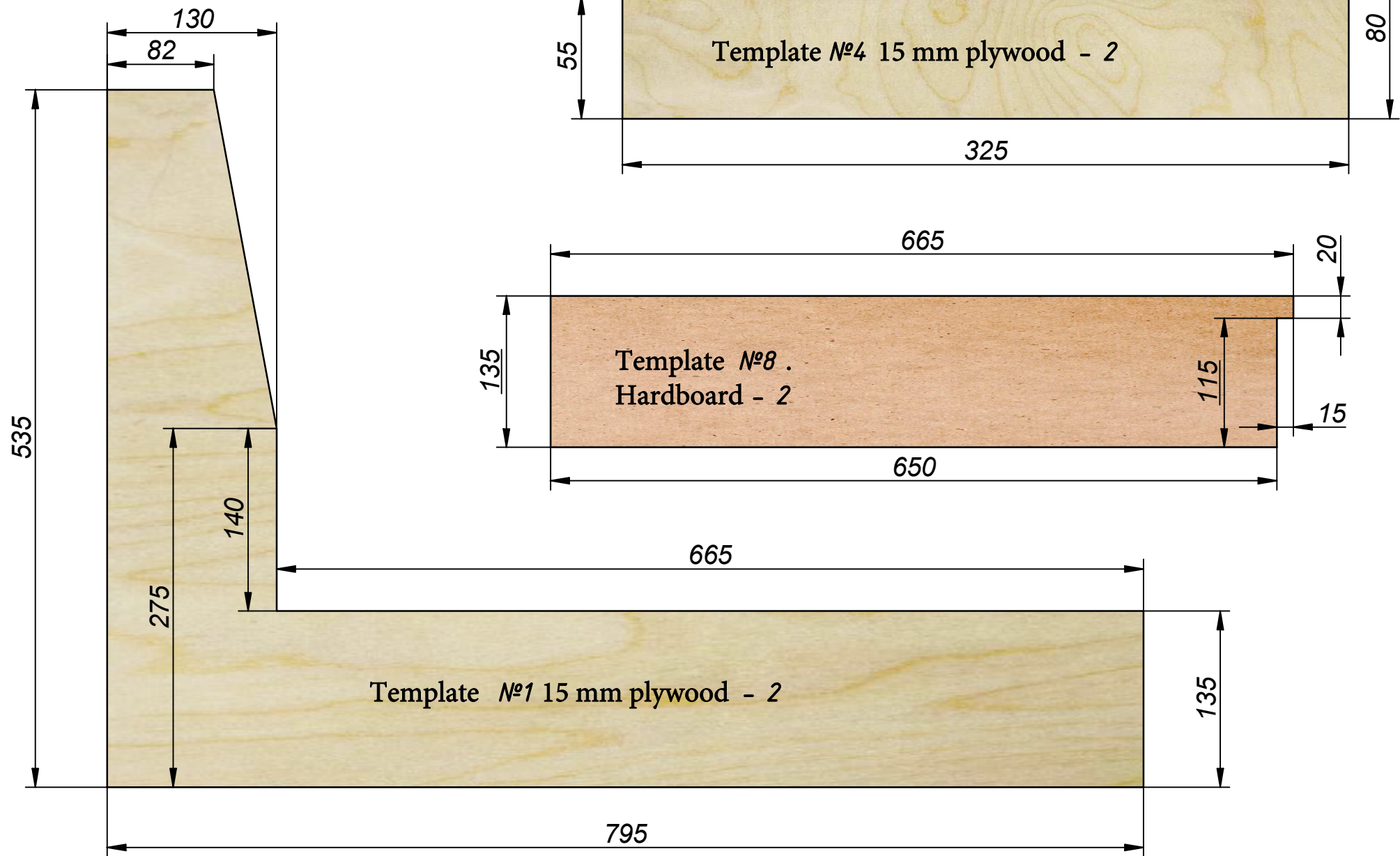

Chesterfield Armchair

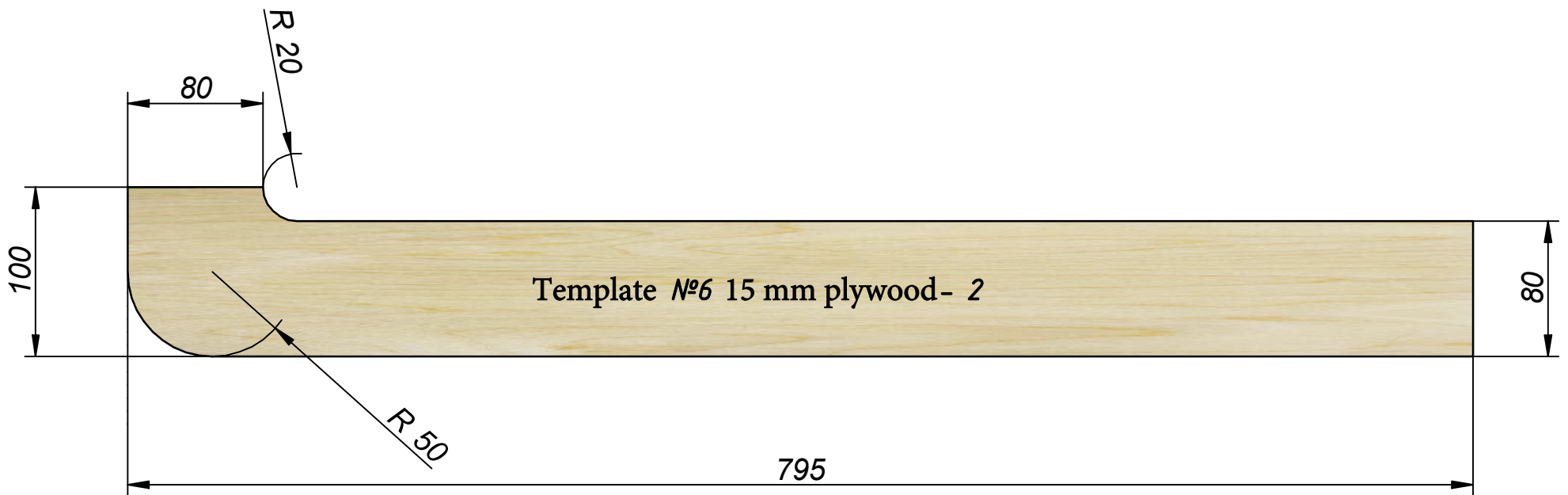
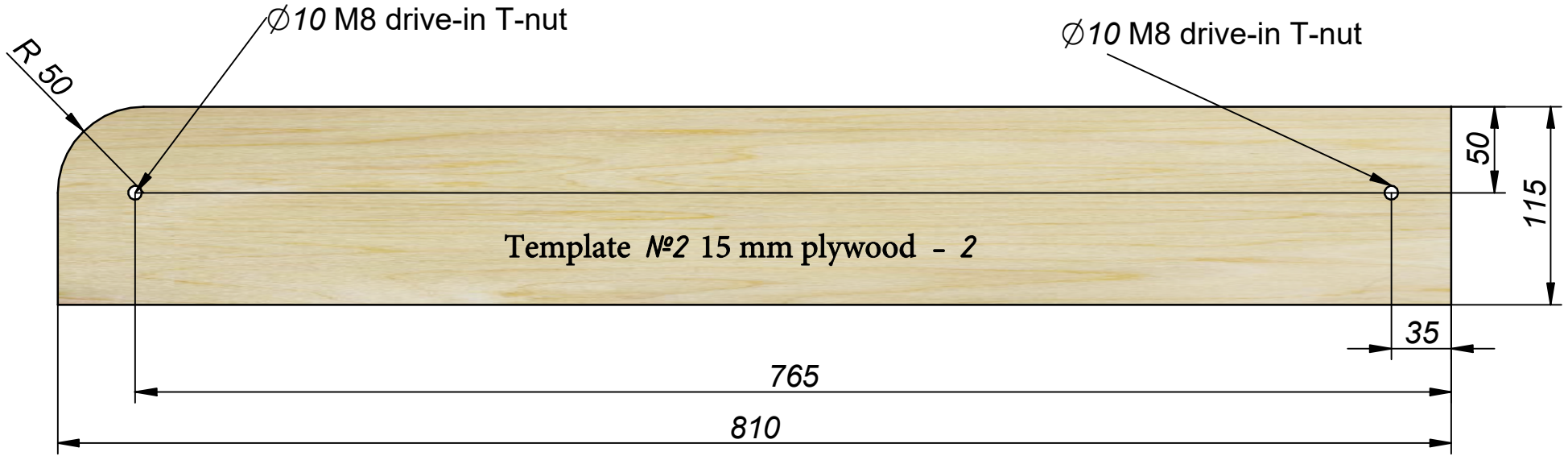

# Template №3 15 mm plywood - 2

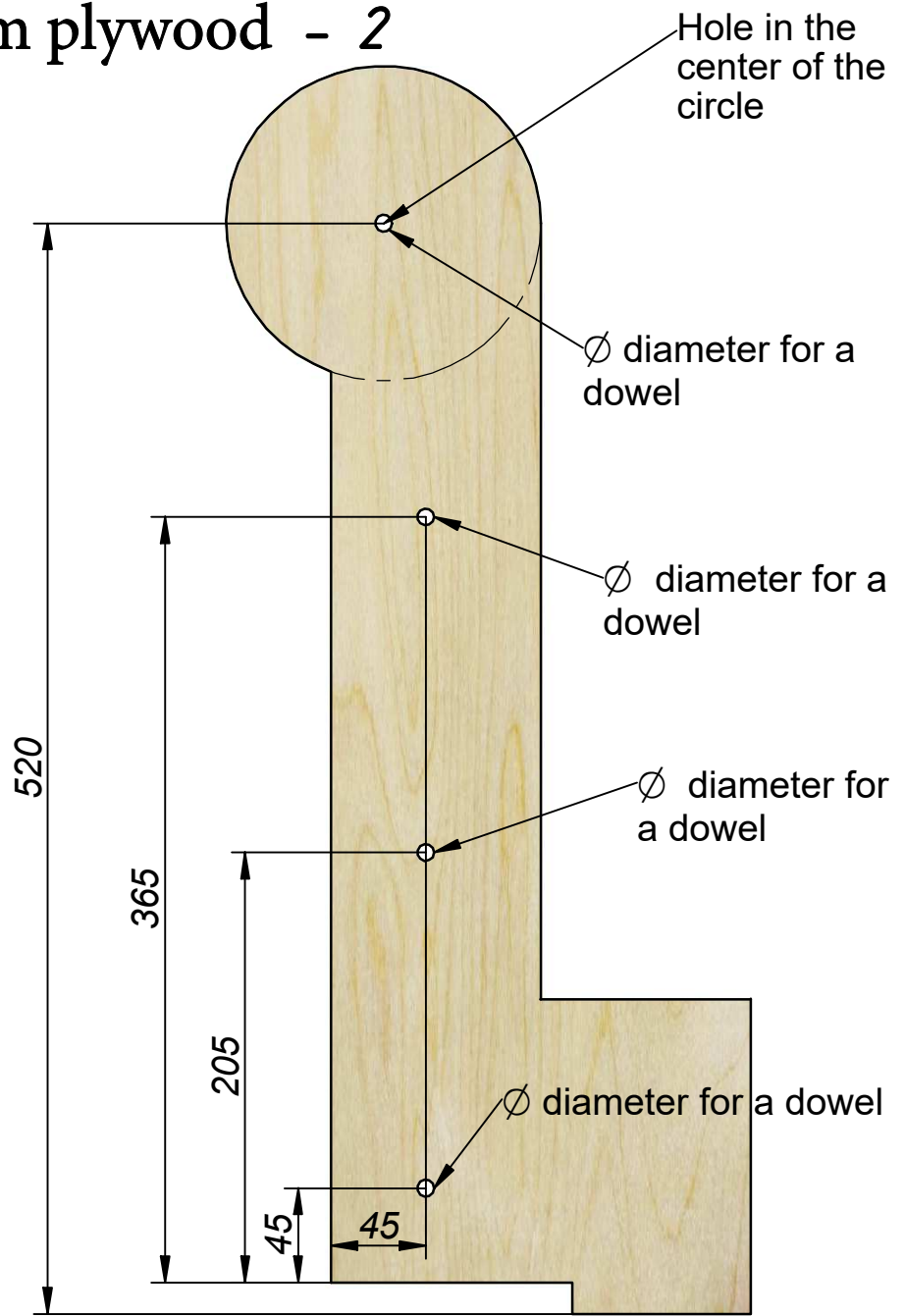
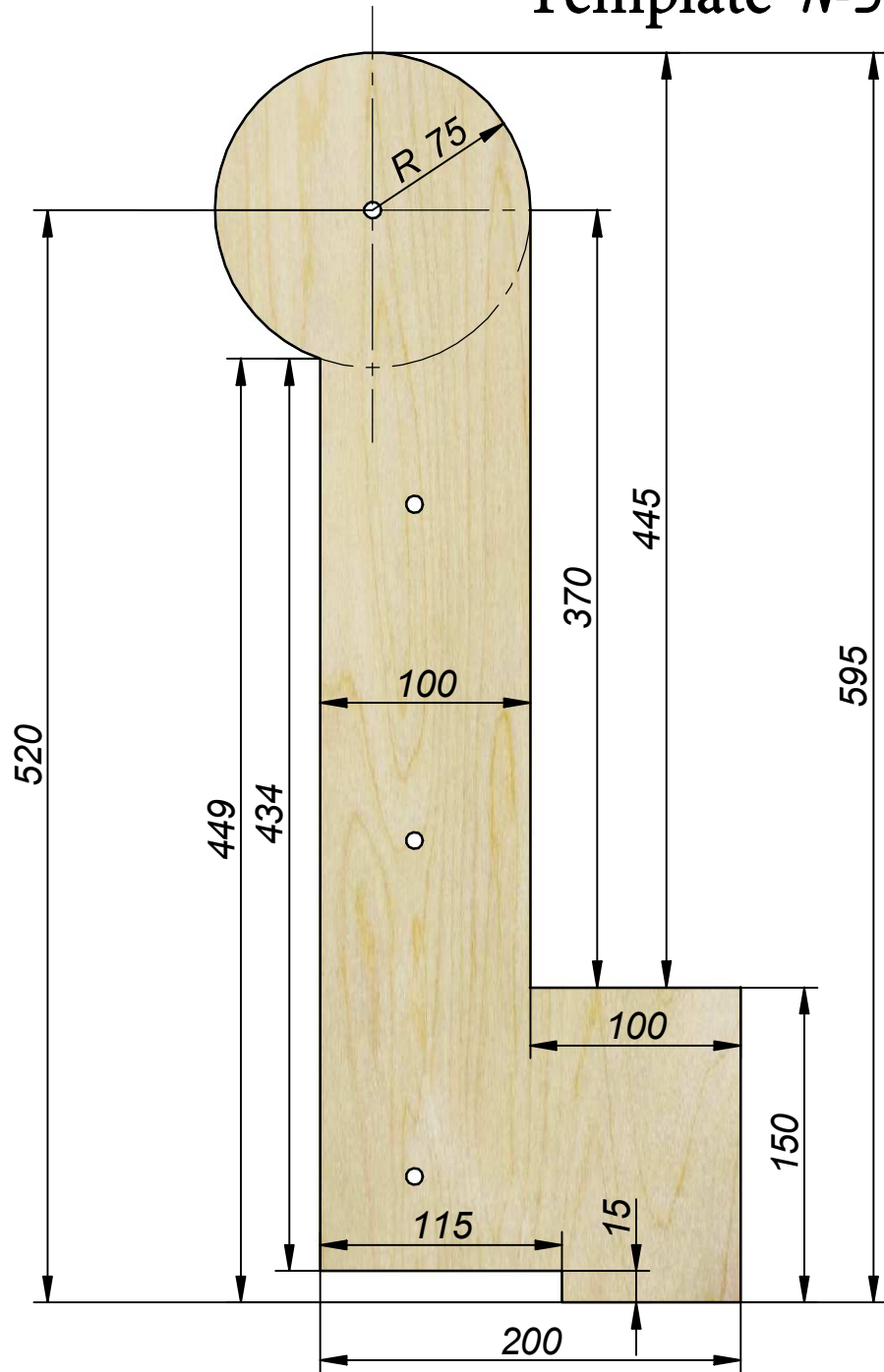

Chesterfield Armchair

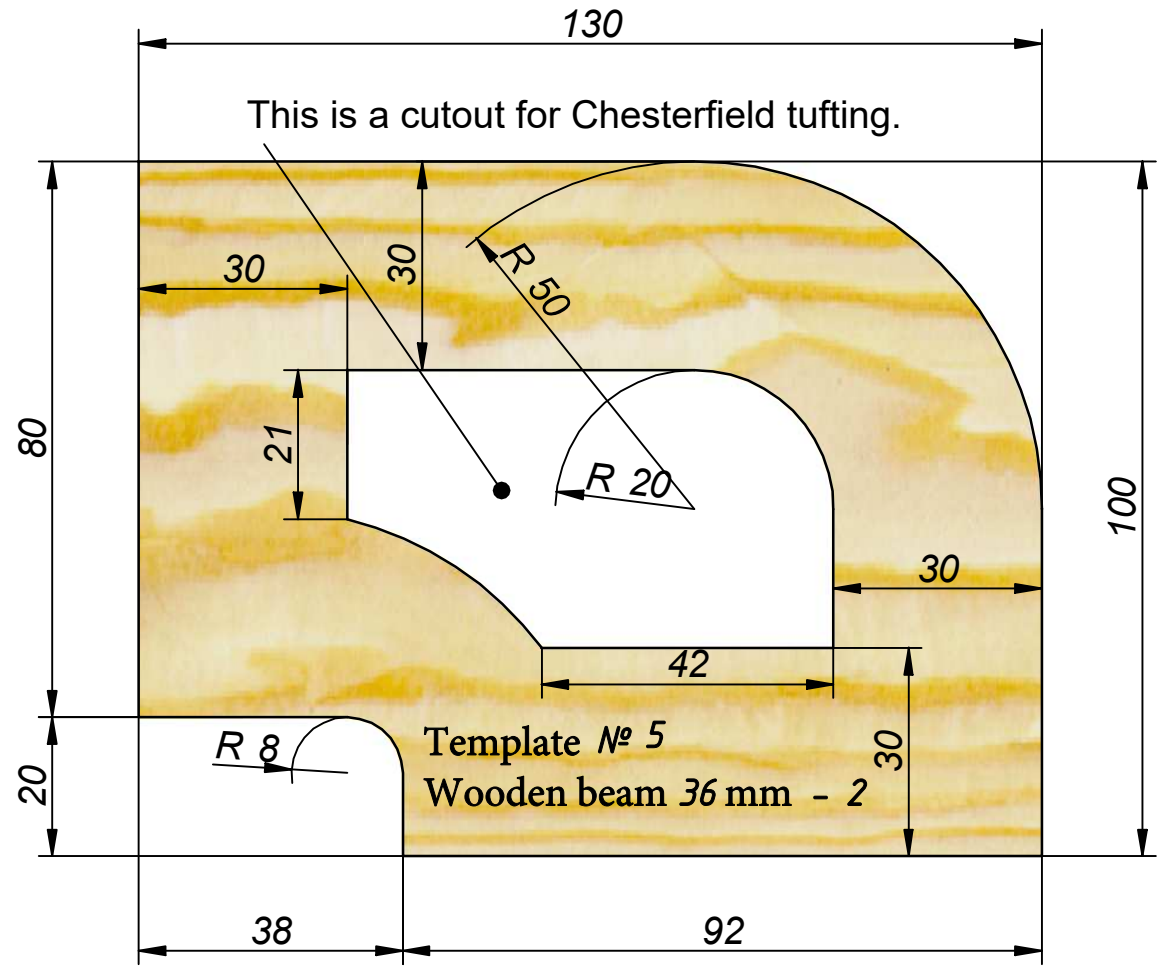
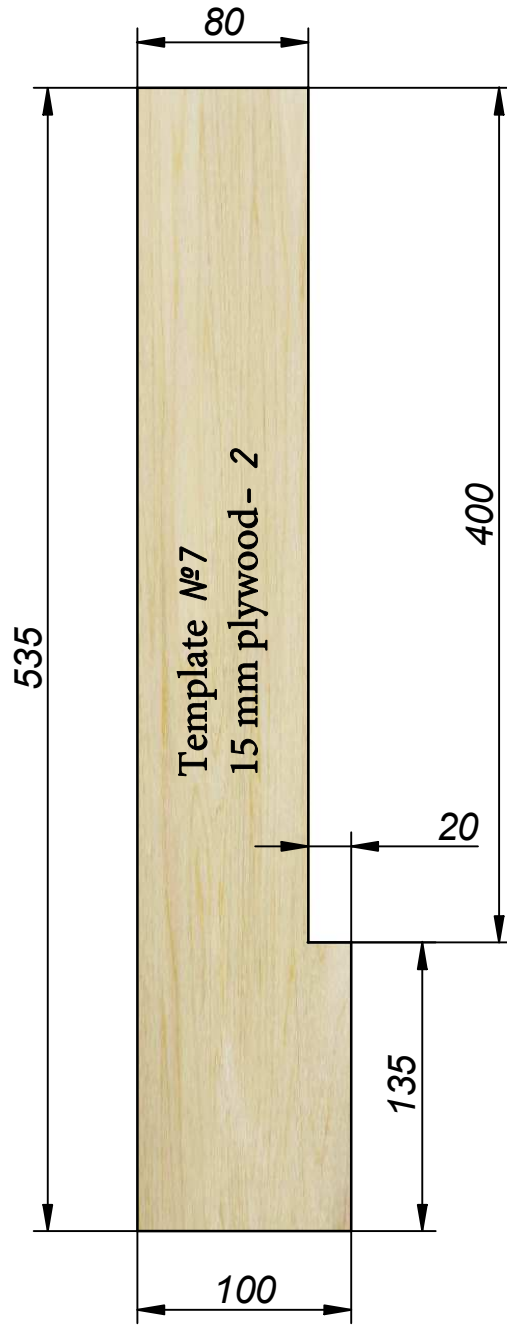

The dimensions of the trim template depend on the thickness of the piping that will be attached along the perimeter of the trim. This template uses piping with an 8 mm diameter. If the piping is larger or smaller than 8 mm in diameter, then the dimensions of the trim template must be adjusted according to the piping diameter. In other words, before cutting the part using the template, you need to clarify which piping diameter will be used.

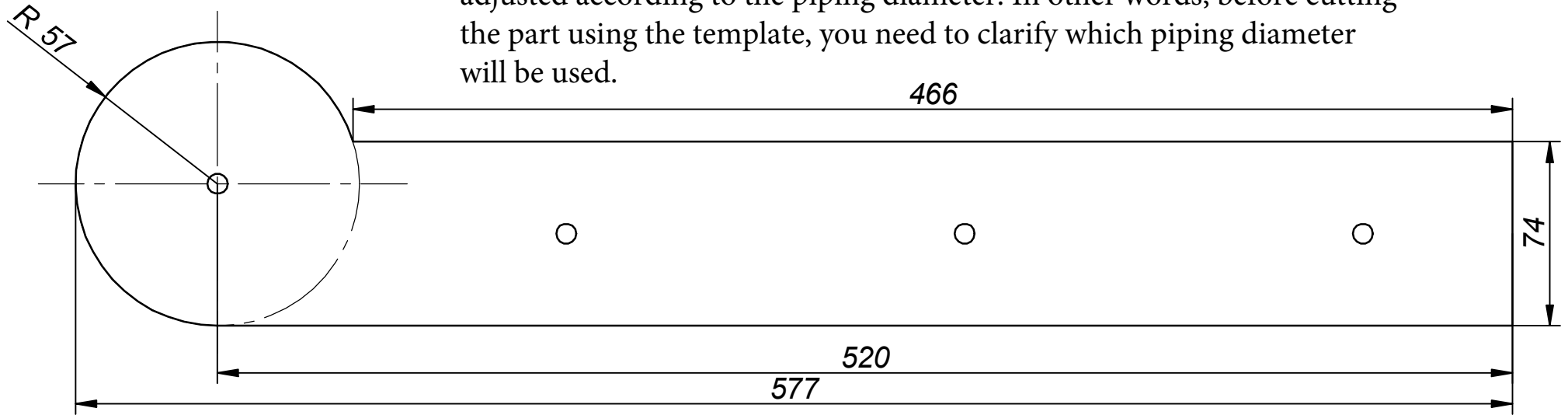

Template №9 10 mm plywood - 2

